

GDR



STANDARD CONFIGURATION



PILOT OPERATED (DOME LOADED)



PIPE-A-WAY CHAMBER



PANEL MOUNTED

SERIES

Description

The GDR Series Regulator provides reliable, precise pressure control in the most demanding applications. Optimized Venturi and spring design assures high flow with extremely low droop characteristics. Solid non-tied diaphragm and all brass construction guarantees leak free long lasting performance. Fully balanced design virtually eliminates outlet pressure fluctuations due to inlet pressure variations. All GDR Series regulators are 100% factory tested.

Features

- Fully Balanced Design maintains a constant delivery pressure regardless of inlet pressure fluctuations
- Fully Supported, Solid Non-Tied Diaphragm for long leak free service life
- Flow Rates to 20,000 SCFH
- Optimized Spring Design and Unique Venturi Tube allows for high flow rates with minimal pressure droop effect
- Pilot Operated (dome loaded) Configuration maintains virtually constant outlet pressures
- Vent Chamber to Stack with Pipe-a-Way Option
- Side Venting Chamber option prevents moisture accumulation when mounted horizontally
- Cleaned and Packaged for Oxygen Service

Note: Regulators supplied with Nitrile Seals are not Cleaned and Packaged for Oxygen Service.

Materials of Construction

- Forged Brass Body and Spring Chamber ASTM 377
- Brass Adjustment Screw, Valve, Valve Stem, Spring Button, Spring Retainer and Venturi Tube ASTM B16
- 303 Stainless Steel Chamber Insert ASTM A276
- Color Coded, Chrome Vanadium Adjustment Springs ASTM A-231
- 302 Stainless Steel Valve Spring ASTM A-313
- GLT Fluoroelastomer (FKM), EPDM, or Nitrile on Nylon Diaphragm
- GLT Fluoroelastomer (FKM), EPDM, or Nitrile Seats and Seals
- Stainless Steel Trim (Flange Screws and Lock Nut)

Note: EPDM seals recommended for CO₂ service. Nitrile Seals recommended for NG service.

GAS DELIVERY REGULATOR

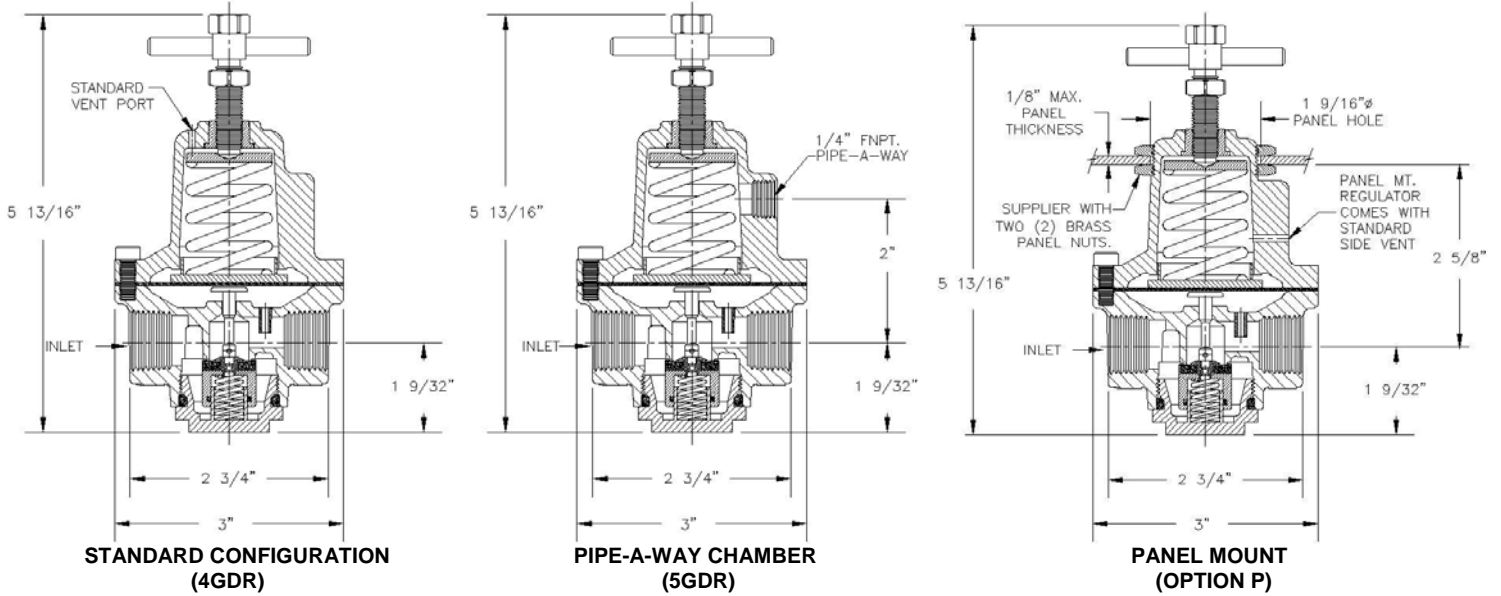

GDR-500 Flow Curve

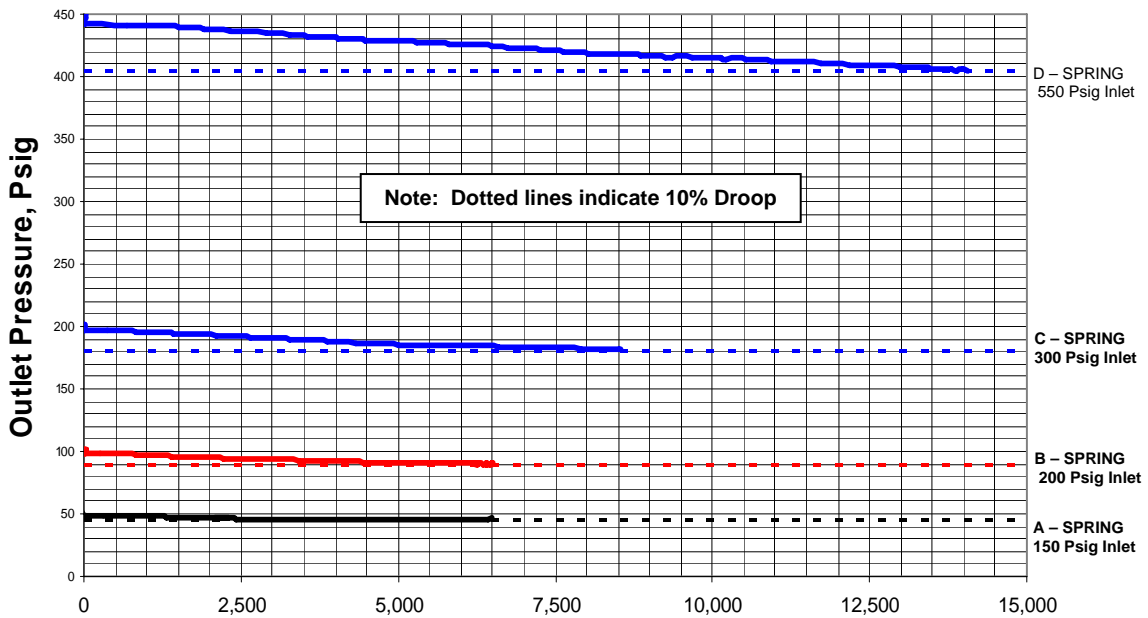

Technical Data (GDR-500)

Maximum Inlet Pressure: 550 Psig (37.9 Bar)
 Effect of Inlet Pressure Variation: < 0.25 Psig/100 Psig

Fail Open Flow Coefficient	Cv
1/4" NPT and BSPT	1.6
3/8" NPT	2.4
1/2" NPT and BSPT	2.9

Pressure Ranges	
Spring Model Code	Outlet Pressure Range
A (Black)	0 - 55 Psig (0 - 3.8 Bar)
B (Red)	50 - 135 Psig (3.5 - 9.3 Bar)
C (Blue)	125 - 225 Psig (8.6 - 15.5 Bar)
D (Blue)	225 - 450 Psig (15.5 - 31.0 Bar)

Notes:
 A, B and C Range Springs are interchangeable
 D Range spring utilizes dedicated Chamber, Chamber Ring and Spring Retainer

GAS DELIVERY REGULATOR

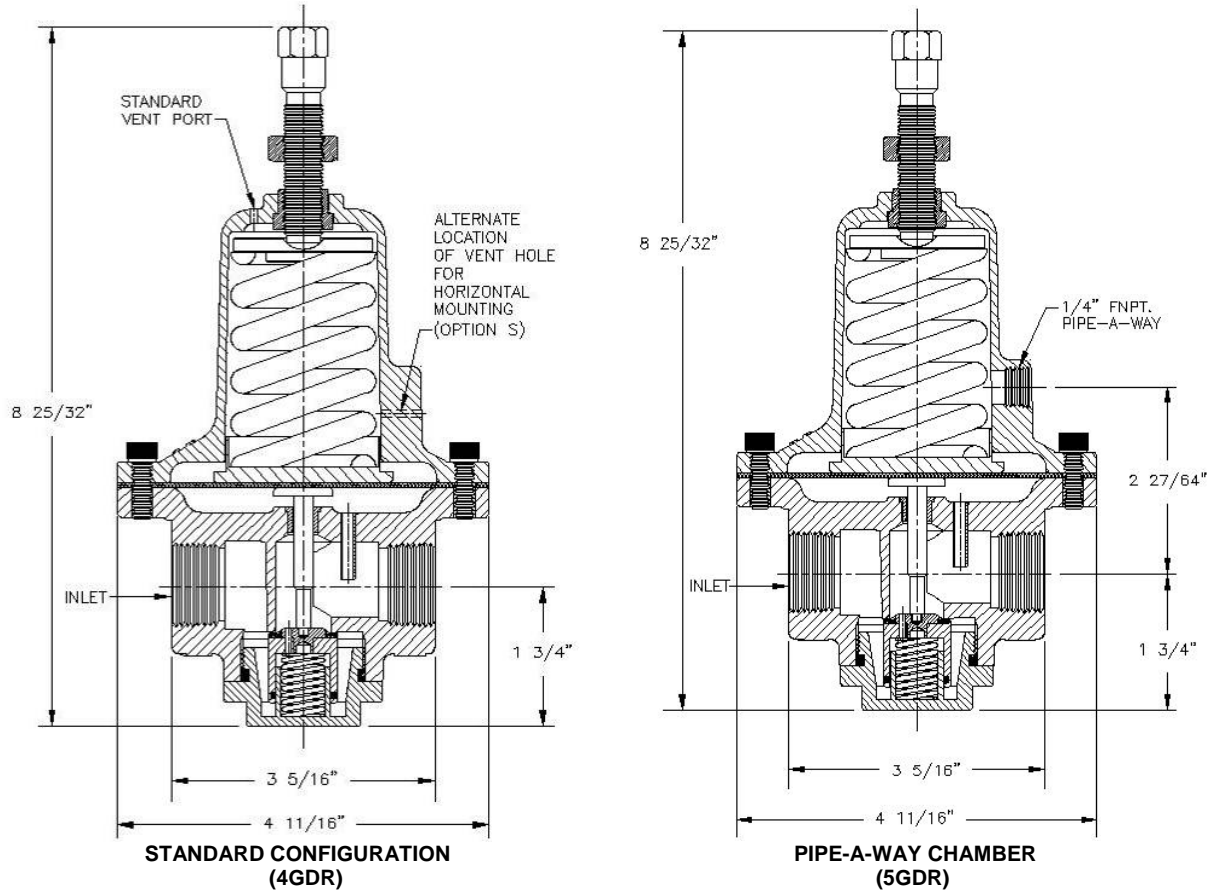

GDR-1000 Flow Curve

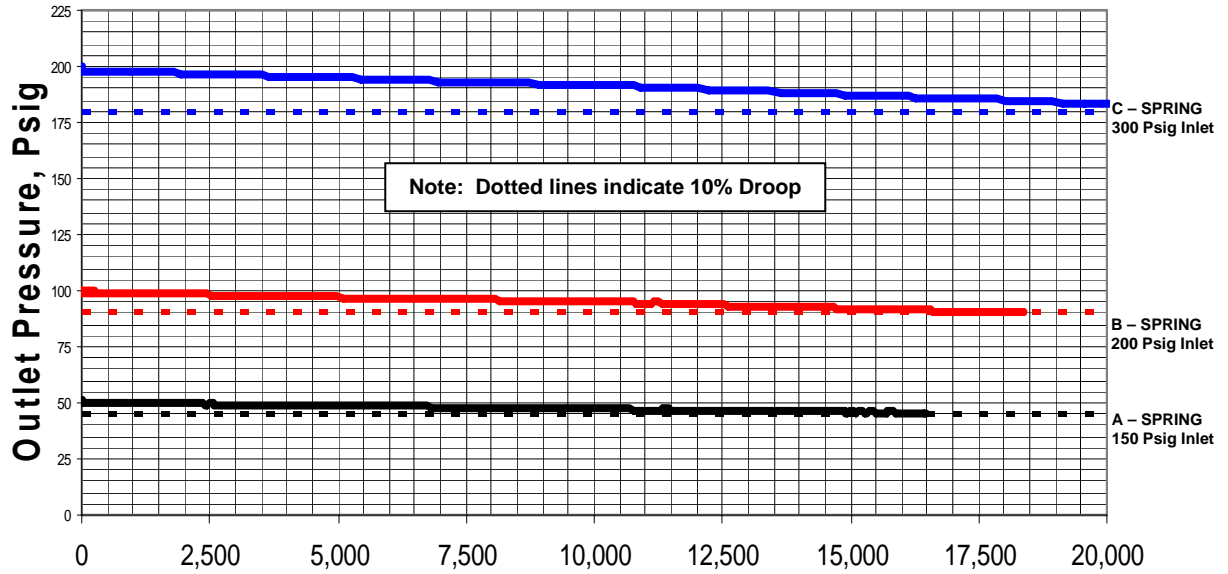

Technical Data (GDR-1000)

Maximum Inlet Pressure: 400 Psig (27.6 Bar)
 Effect of Inlet Pressure Variation: < 0.25 Psig/100 Psig
 Fail Open Flow Coefficient (3/4 and 1"): 5.8 Cv

Pressure Ranges	
Spring Model Code	Outlet Pressure Range
A (Black)	0 - 55 Psig (0 - 3.8 Bar)
B (Red)	50 - 135 Psig (3.5 - 9.3 Bar)
C (Blue)	125 - 225 Psig (8.6 - 15.5 Bar)

Notes: A, B and C Range Springs are interchangeable

GAS DELIVERY REGULATOR

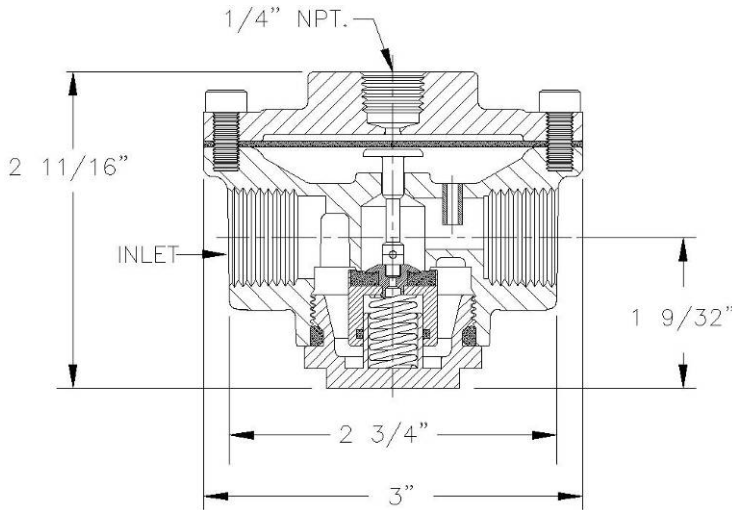

GDR-500, Pilot Operated

Maximum Pilot Pressure: 450 Psig (31.0 Bar)
 Maximum Usable Cv: 1.5
 Pilot Pressure to Outlet Pressure Ratio: 1 : 0.95
 (100 Psig Pilot Pressure = 95 Psig Outlet Pressure)

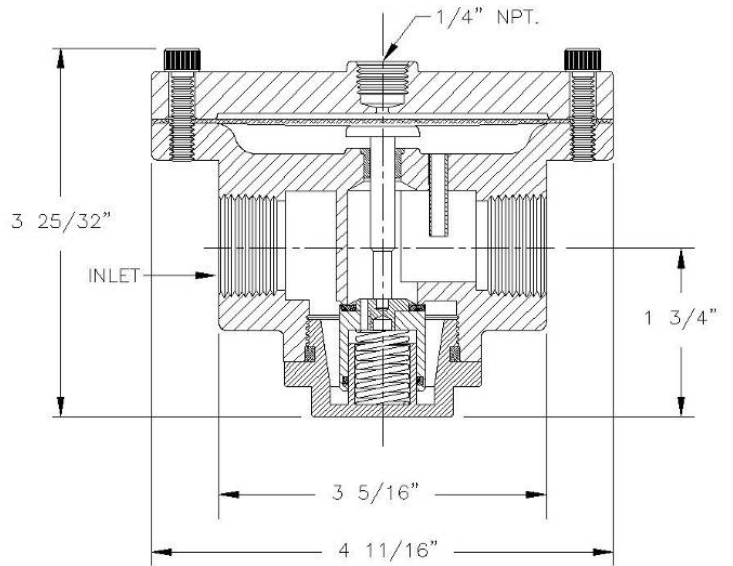

GDR-1000, Pilot Operated

Maximum Pilot Pressure: 350 Psig (24.1 Bar)
 Maximum Usable Cv: 2.7
 Pilot Pressure to Outlet Pressure Ratio: 1 : 0.90
 (100 Psig Pilot Pressure = 90 Psig Outlet Pressure)

Pilot Operated Regulators fail closed on loss of pilot pressure. Regulators fail open on loss of outlet pressure when pilot pressure is present.

How To Order

4GDR - 750B - V - A - S

SERIES

4GDR - 4 Port Gas Delivery Regulator
 5GDR - 4 Port Gas Delivery Regulator
 w/ Pipe-A-Way Chamber*

* - Pipe-A-Way Chambers are 1/2" FNPT

OPTION

S - Side Vent
 W - Hex Adj. Screw
 P - Panel Mount

Available for GDR-500 Only

OUTLET PRESSURE RANGE

A - 0 to 55 Psig
 B - 50 to 135 Psig
 C - 125 to 225 Psig
 D - 225 to 450 Psig

Available for GDR-500 Only

PORT SIZE

250B - 1/4" FNPT
 375B - 3/8" FNPT
 500B - 1/2" FNPT
 2BSPT - 1/4" BSPT
 4BSPT - 1/2" BSPT

Available for GDR-500 Only

SEALS/DIAPHRAGM MATERIAL

V - GLT Fluoroelastomer (-20°F to 225°F)
 EP - EPDM - CO2 Service (-60°F to 225°F)
 B - Nitrile - NG Service (-40°F to 225°F)

■ - Available for GDR-500 only

Repair Kits

Includes: Valve Stem, Diaphragm, Valve Assembly, Valve Spring and Bottom Plug O-Ring

Model Size	Seal Material	Specify
1/4", 3/8" & 1/2"	FKM	GDR-RK-1V
	EPDM	GDR-RK-1EP
	Nitrile	GDR-RK-1B
3/4" & 1"	FKM	GDR-RK-2V
	EPDM	GDR-RK-2EP
	Nitrile	GDR-RK-2B

* -FKM and EPM Kits are cleaned for Oxygen Service.

Replacement Spring Kits

Includes: Spring (3/4" & 1" kit includes corresponding spring retainer)

Model Size	Specify
1/4", 3/8" & 1/2"	GDR-SK-1-*
3/4" & 1"	GDR-SK-2-*

* -Specify Spring Model Code: A, B, C, or D

Note:
 All Regulators are supplied with 2 (two) 1/4" NPT Pipe Plugs. Pipe plugs are supplied finger tight.
 Final installation is the responsibility of the end user.

PROPER COMPONENT SELECTION – When specifying a component, the total system design must be considered to ensure safe and trouble-free performance. Intended component function, materials compatibility, pressure ratings, installation, environment and maintenance are the responsibility of the system designer.

GENERANT

www.generant.com

1865 Route 23 South PO Box 768 Butler, New Jersey 07405 973.838.6500 Fax 973.838.4888